

MAS.836 Sensor Systems for Interactive Environments

Distributed : Thursday February 28th, 2008

Due : Thursday March 13th, 2008

Homework Set #2 : Rev A

Time Varying Circuit Analysis

The purpose of this problem set is to introduce capacitors, which are dependent on time-varying signals, $V_{in}(t)$. The feedback op-amp circuits that were introduced in problem set 1 also have time varying dependencies. The other time varying circuit fundamentals this problem set will explore is the concepts of op-amps with positive feedback. To complete this problem set, you will need to know the following:

Complex Frequency Analysis: Calculations involving time varying circuits are greatly simplified by the use of complex math. Two special symbols are used in the complex math for this discussion. The complex factor is denoted with the letter j , where $j = \sqrt{-1}$. To represent frequency the ω symbol is used, with units of radians per second. The relationship between ω and the frequency f with units of hertz is, $2\pi f = \omega$. Remembering to multiply by 2π when calculating capacitor values is very important. To calculate the amplitude of the sum of signals which are shifted out of phase by j , you do the following:

For some signal with complex amplitude:

$$A_c = \frac{b + c \cdot j}{d + e \cdot j} \quad (1)$$

the actual amplitude you would see on your oscilloscope would be:

$$\text{Magnitude} = |A_c| = \frac{\sqrt{b^2 + c^2}}{\sqrt{d^2 + e^2}} \quad (2)$$

For more information on complex math, refer to [1] pages 28-41. Complex math is also covered in many college level math texts.

Capacitor Impedance : The capacitor can be thought of as a frequency dependent resistor. As frequency increases, the effective resistance decreases. At very high frequencies, the capacitor is equivalent to a 0Ω resistor or a short-circuit. And, conversely, at very low frequencies, the capacitor acts like an open circuit. Note how $V = i \cdot \frac{1}{j\omega C}$ is related to the resistor equivalent of $V = i \cdot R$. An unconnected capacitors relationship between frequency and impedance is as follows:

$$V = \frac{1}{C} \int i dt = \frac{1}{j\omega C} \cdot i \quad (3)$$

$$i = C \frac{dV}{dt}, C_{impedance} = \frac{1}{j\omega C} \quad (4)$$

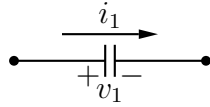

Figure 1: Symbol for a capacitor with voltage and current notation.

Non-Ideal Op-amp Model: The ideal op-amp model was presented in problem set one. Op-amp voltage outputs are limited by the voltage of the power supply of the op-amp. The op-amp can not create a V_{out} which is larger than the positive supply ($+V_s$), or a V_{out} which is lower than the negative supply ($-V_s$). If the op-amp tries to swing outside of the supply voltages, it merely 'saturates' (the output remains at the maximum possible voltage, either at $(+V_s)$ or $(-V_s)$). Op-amps that saturate to the maximum and minimum supply voltages are called 'rail-to-rail' op-amps. Some op-amps are only able to saturate within $\approx 3V$ of the supply voltages! Be sure to carefully check the limitations of the selected op-amp.

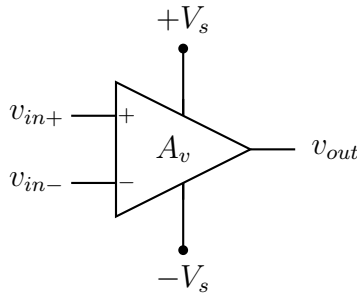

Figure 2:

$$-V_s < V_{out} = A_v ((v_{in+}) - (v_{in-})) < +V_s \quad (5)$$

Without negative feedback, (v_{in+}) can not be assumed to be the same as (v_{in-}) . Instead the relationship $V_o = A_v((v_{in+}) - (v_{in-}))$ must be used to calculate the output voltage. When the op-amp design is configured for positive feedback, this calculation simplifies to:

$$V_o = +V_s, \text{ when } v_{in+} > v_{in-} \quad (6)$$

$$V_o = -V_s, \text{ when } v_{in+} < v_{in-} \quad (7)$$

Any difference between v_{in+} and v_{in-} will cause the op-amp to saturate because A_v is very large.

Problem 1

A decibel (dB) is defined as the power (P) ratio between two signals. Decibels are useful in cases where the power ratio may span many decades, as (dB) has a logarithmic response ([1] p. 16).

$$dB = 10 \cdot \log_{10} \left(\frac{P_1}{P_2} \right), \text{ where the log is base 10.} \quad (8)$$

for example:

$$40dB = 10 \cdot \log_{10} \left(\frac{1 \cdot 10^6}{100} \right) \quad (9)$$

In a lot of cases we are interested in the ratio of voltages or currents, rather than the ratio of powers. Ratios of voltages or currents may still span over many decades, thus making decibel representation useful. For consistency, the voltages must be converted into powers, which will give the following relation:

$$P = V \cdot I = \frac{V^2}{R} = I^2 \cdot R \quad (10)$$

$$dB = 10 \cdot \log_{10} \left(\frac{P_1}{P_2} \right) \quad (11)$$

$$= 10 \cdot \log_{10} \left(\frac{V_1^2/R}{V_2^2/R} \right) \quad (12)$$

$$= 10 \cdot \log_{10} \left(\left(\frac{V_1}{V_2} \right)^2 \right) \quad (13)$$

$$= 20 \cdot \log_{10} \left(\frac{V_1}{V_2} \right) \quad (14)$$

$$\text{similarly, } dB = 20 \cdot \log_{10} \left(\frac{I_1}{I_2} \right) \quad (15)$$

for example

$$60dB = 20 \cdot \log_{10} \left(\frac{1mA}{1\mu A} \right) \quad (16)$$

Since A_v deals with a voltage gain, and not a power gain, you will use this latter equation to answer the following questions. The large signal voltage gain (A_v) of the op-amp you will be using for your labs is listed as $100dB$.

- a. What is A_v in $V/\mu V$? Note that most datasheets either list A_v in terms of dB or $V/\mu V$.
- b. If you are using this op-amp in a circuit with $+V_s = 5V$ and $-V_s = 0V$, what is the maximum input differential ($v_{in+} - v_{in-}$) which it can handle before it saturates?

Problem 2

The following circuit is known as a comparator. It is very useful for performing single bit analog to digital AtoD conversion, or informing some other part of the circuit whether or not a voltage has crossed a certain threshold. The input may be placed into either the inverting or non-inverting input. Please use this circuit to answer the following questions.

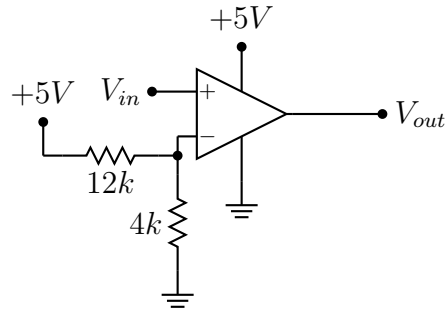

Figure 3: Comparator circuit.

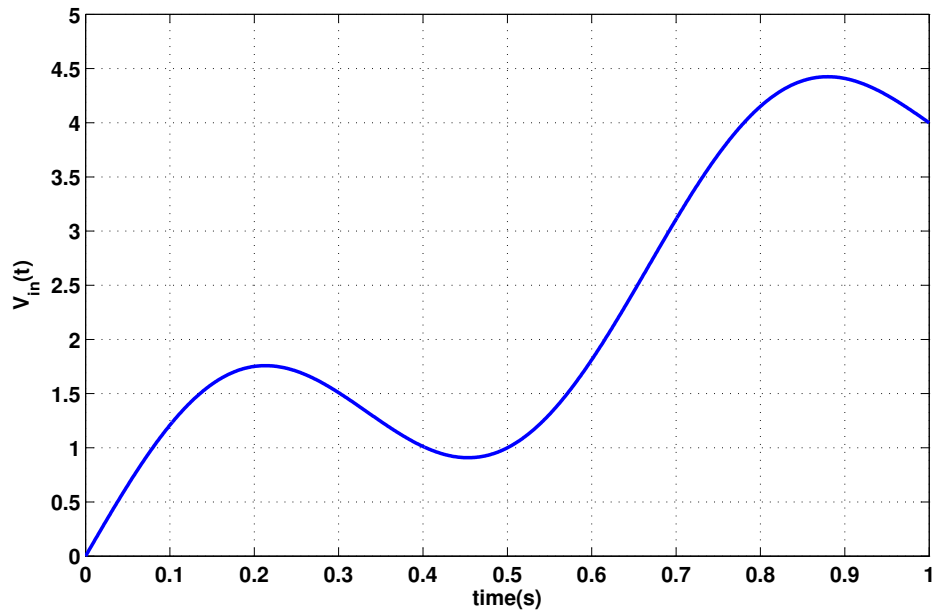

Figure 4: Plot of V_{in} over time for problem (d).

-
- a. What is the value of the voltage at v_{in-} ?

- b. Will v_{in-} vary with time?
- c. Plot v_{in-} versus time on the graph below.
- d. Given the plot of V_{in} below, plot V_{out} as a function of time.

Problem 3

The previous op-amp circuit is susceptible to false triggering due to noise on the input signal (note your answer to Problem One, part b). To eliminate this, you can use a resistor in positive feedback to pull your reference voltage in one direction or another. This configuration, shown below, is called a Schmitt trigger input, and it creates hysteresis to debounce an input signal. Please use the circuit below to answer the following questions (note that the op-amp's inputs have been switched from the problem two's circuit.).

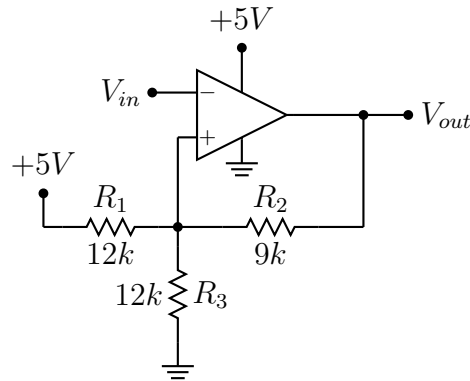

Figure 5: Schmitt triggered input design for problem 3.

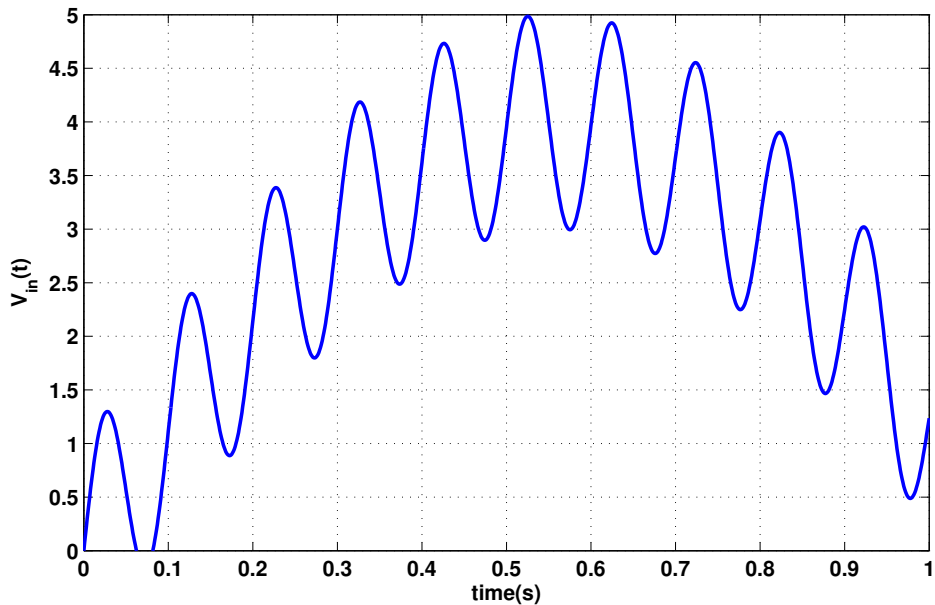

Figure 6: Plot of V_{in} over time for problem 3.

-
- If $V_{out} = 5V$, i.e. is saturated to $+V_s$, what is the value of v_{in+} ?
 - If $V_{out} = 0V$, i.e. is saturated to $-V_s$, what is the value of v_{in+} ?
 - Using dashed lines, plot both values of v_{in+} from part (a) and (b) as constant voltages versus time on the graph below.
 - If $V_{in} = 0V$, what is V_{out} ?
 - Given the plot of V_{in} below, plot V_{out} and v_{in+} as a function of time.
-

Problem 4

The following circuit is an RC low-pass filter, as it uses a resistor and a capacitor to pass low frequencies, and attenuate high frequencies. The defining characteristic of an RC filter is its cut-off frequency, which is when the circuit transitions from passing one set of frequencies, and attenuating another. This happens at the point where the magnitude of the real impedance presented by the resistor equals the magnitude of the complex impedance presented by the capacitor ($C_{\text{impedance}} = \frac{1}{j\omega C}$). Please answer the following questions.

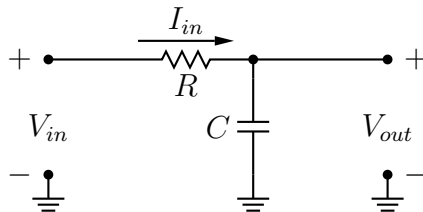

Figure 7: Circuit for problem 4.

- What is the input impedance $\frac{V_{in}}{I_{in}}$ at DC ($0Hz$)?
- What is the input impedance at infinite frequency?
- What is the transfer function $\frac{V_{out}}{V_{in}}$ of this circuit as a function of R , C , j , and ω ?
- What is the cut-off frequency of this circuit in rad/s ?
- What is the magnitude, as described in the Complex Frequency Analysis section, of your result from part (d) at its cut-off frequency?
- What is the value of V_{out} at DC?

- g. What is the value of V_{out} at infinite frequency?
- h. For high frequencies, such that $\omega \gg 1/(R \cdot C)$, what is the ratio, in dB , of the amplitude of V_{out} at ω to the amplitude of V_{out} at 10ω ? (This is called the roll-off).

Problem 5

The following circuit is an RC high-pass filter, so called because it passes high frequencies, and attenuates low frequencies. It follows the same rules as described in problem four. Please answer the following questions.

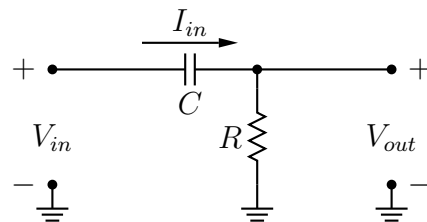

Figure 8: Circuit for problem 5.

- a. What is the input impedance $\frac{V_{in}}{I_{in}}$ at DC ($0Hz$)?
- b. What is the input impedance at infinite frequency?
- c. What is the transfer function $\frac{V_{out}}{V_{in}}$ of this circuit as a function of R , C , j , and ω ?
- d. What is the value of V_{out} at DC?
- e. What is the value of V_{out} at infinite frequency?
- f. For low frequencies, such that $\omega \ll 1/(R \cdot C)$, what is the ratio, in dB , of the amplitude of V_{out} at ω to the amplitude of V_{out} at 10ω ?
- g. If $R = 2.2k\Omega$, and $C = 2nF$, what is the cut-off frequency of this circuit in Hertz?

Problem 6

In this problem you will design a Multiple Feedback (MFB) band-pass filter. Review chapter 16 of [2]. Note that to bias an MFB bandpass op-amp's output, the (v_+) terminal can be set to the middle voltage range with a voltage divider. See Mark Feldmeier's op-amp biasing notes on the class web-page. Now design a MFB band-pass filter with one op amp and the following parameters. Check your design, which you will calculate manually, with the Analog Devices *Interactive Design Tools: OpAmps : Active Filter Synthesis* tool, which is linked to on the course web-site.

- a. Uses feedback capacitors $C = 2.2nF$,
 - b. has a center frequency f_m of $2.5kHz$,
 - c. has a gain at the center frequency of $-A_m = 3$,
 - d. has a band-width of $500Hz$,
 - e. runs off a single $5V$ supply (i.e. $+V_s = 5V$ and $-V_s = 0V$), and
 - f. has an output which is centered at $2.5V$.
 - g. Calculate the quality factor Q .
-

References

- [1] P. Horowitz and W. Hill, *The Art of Electronics*. New York: Cambridge University Press, 1989.
- [2] R. Mancini, *Op Amps for Everyone : Design Reference*. Dallas, Texas: Texas Instruments, 2002.